

ULTRA HIGH SPEED SWITCHING APPLICATION.

### FEATURES

- Small Package : USC.
- Low Forward Voltage.
- Fast Reverse Recovery Time.
- Small Total capacitance.

### MAXIMUM RATINGS (Ta=25°C)

CHARACTERISTIC	SYMBOL	RATING	UNIT
Maximum (Peak) Reverse Voltage	$V_{RM}$	85	V
Reverse Voltage	$V_R$	80	V
Maximum (Peak) Forward Current	$I_{FM}$	300	mA
Average Forward Current	$I_O$	100	mA
Surge Current (10mS)	$I_{FSM}$	2	A
Power Dissipation	$P_D$	-	mW
Junction Temperature	$T_j$	150	°C
Storage Temperature Range	$T_{stg}$	-55 ~ 150	°C

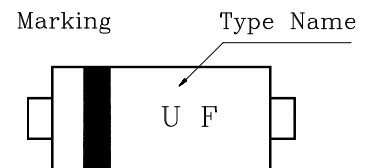
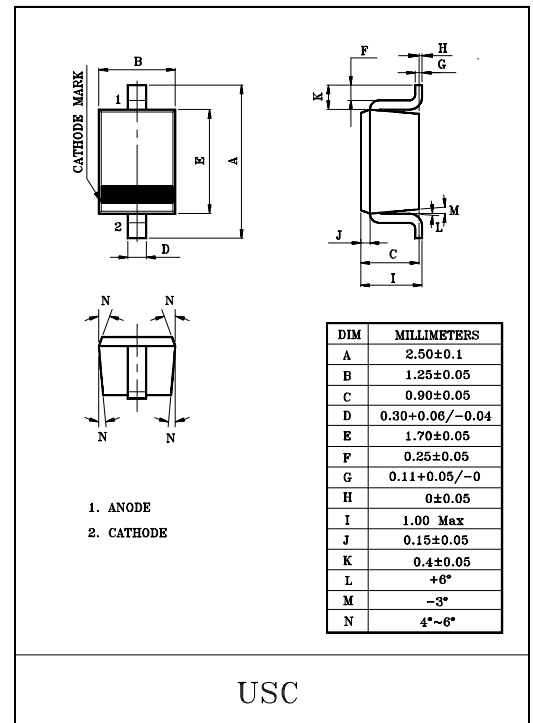

### ELECTRICAL CHARACTERISTICS (Ta=25°C)

CHARACTERISTIC	SYMBOL	TEST CONDITION	MIN.	TYP.	MAX.	UNIT
Forward Voltage	$V_{F(1)}$	$I_F=1mA$	-	0.60	-	V
	$V_{F(2)}$	$I_F=10mA$	-	0.72	-	
	$V_{F(3)}$	$I_F=100mA$	-	0.90	1.20	
Reverse Current	$I_R$	$V_R=80V$	-	-	0.5	μA
Total Capacitance	$C_T$	$V_R=0V, f=1MHz$	-	0.9	3.0	pF
Reverse Recovery Time	$t_{rr}$	$I_F=10mA$	-	1.6	4.0	nS