



Shenzhen DTP Battery Co.,Ltd

Title	Polymer Lithium Ion Battery		
File No	523453-1050mAh	Ver 1.0	Page: 1/10

Polymer Li-ion Battery Product Specifications

Revision History

REVISION	DATE	ORIGINATOR	REASON FOR REVISION
1.0	2010-3-26	Li Dongming	Original Release

TO:

Customer Approval

Comment:

Customer's Signature/Data:

Prepared	Reviewed	Approved
Li Dongming	Wan Gang	Ling Zhehou
Date: 2010-3-26	Date: 2010-3-26	Date: 2010-3-26



Shenzhen DTP Battery Co.,Ltd

Title	Polymer Lithium Ion Battery		
File No	523453-1050mAh	Ver 1.0	Page: 3/10

4	Circuit Diagram.....	7
13	Product Responsibility Agreement.....	8
14	Precaution Before Charging	8
15	Handling precautions on Lithium ion secondary cell	8
16	Company Information.....	9

1. Scope

This specification shall be applied to be delivered for Customer's type.

2. Product Name and Product Type

2.1 Product Name

Polymer Li-ion Battery

2.2 Product Type

523453-1050mAh

3. Product Specifications

No.	Item	Specification
1	MIN Capacity	1050mAh
2	Typical Capacity	1050mAh
3	Nominal Voltage	3.7V
4	Charge Limited Voltage	4.20 ^{+0.03} _{-0.02} V
5	Discharge Cut-off Voltage	The min is 2.45V, and the standard is 2.55V.
6	End-of-charge Current	10mA
7	Standard Charge	Constant Current: 1C(1050mA) Constant Voltage: 4.2V End-of-charge Current: 10mA
8	Standard Discharge	Using 0.2C(200mA) constant current discharge to the Discharge Cut-off Voltage. Quickly discharge current: 1C(1050mA)
9	Maximum Continuous Charge Current	1C (1050mA)
10	Maximum Continuous Discharge Current	1C (1050mA)
11	Operating Temperature Range	Charge: 0 ~ 45
		Discharge: - 20 ~ 60
	Storage Temperature Range	-20 ~ 60
12	Operating And Storage Humidity Range	Less than 85%RH
13	Weight	20.0g or less



Shenzhen DTP Battery Co.,Ltd

Title	Polymer Lithium Ion Battery		
File No	523453-1050mAh	Ver 1.0	Page: 4/10

4. External Dimension

Thickness: Max5.50mm(Initial 50% charged ,at 20 ± 5)

Width: $34.0 \pm 0.5\text{mm}$

Height: Max:53.5mm

5. External Dimension Drawing

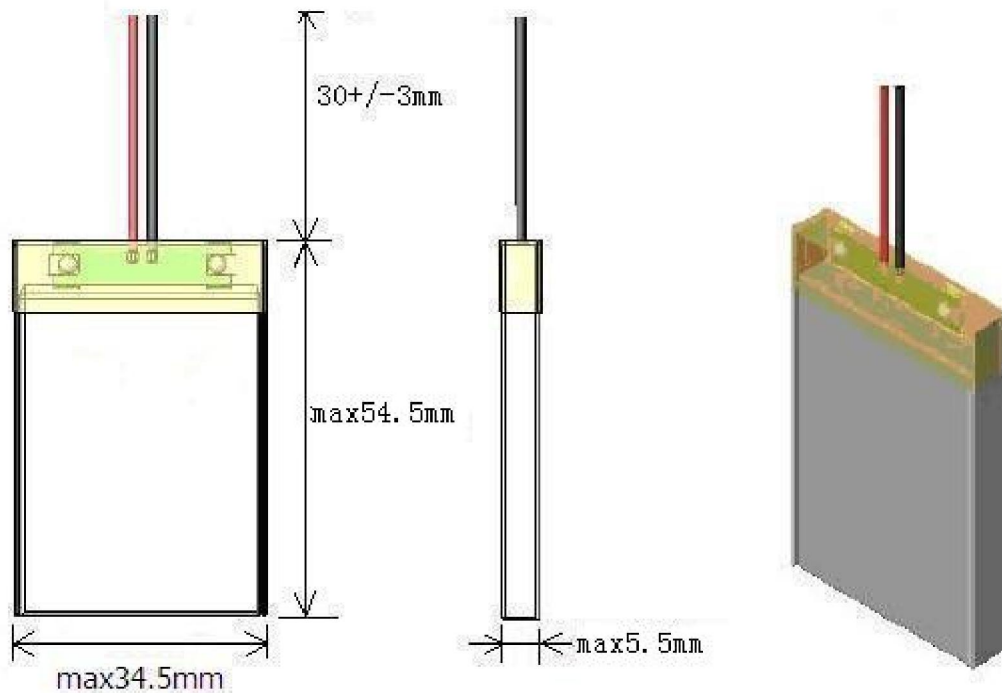

6. Outside Appearance

It shall be free from any defects such as remarkable scratches, breaks, cracks, discoloration, leakage, or deformation, and it shall be clean.



Shenzhen DTP Battery Co.,Ltd

Title	Polymer Lithium Ion Battery		
File No	523453-1050mAh	Ver 1.0	Page: 5/10

7. Basic Electrical Characteristics

No.	Items	Criteria	Test Conditions
1	Open Circuit Voltage	3.75~3.90V	Measure cells at 20 ± 5 after received
2	Internal Impedance	65m	Measure cells using an alternate current impedance meter at 1kHz at 20 ± 5 after received.
3	Rated Capacity (0.2C _{5A})	1050mAh	Standard discharged after the standard charged cells rest 10min at 20 ± 5 . Three cycles are permitted.
4	High Rated Capacity	1050mAh	Discharged at 1C _{5A} rate after the standard charged cells rest 10min at 20 ± 5 . Three cycles are permitted.
5	Temperature Characteristics	Retention Capacity: 60 95% * initial capacity 0 80% *initial capacity -20 60% * initial capacity Appearance: No deformation, leakage, ruptures.	Measured the high rate capacity as the initial capacity. Stored the recharged cells for 3 hrs at 60 ± 2 , 0 ± 2 , -20 ± 2 , and then quickly discharged at this temperature, but Standard discharged at -20 ± 2 exceptionally. Checked the cells' appearance after rest for 2 hrs at room temperature.
6	Storage Characteristics	Retention Capacity: 80% initial capacity impedance increase: 40m Swelling: 0.5mm Appearance: No leakage Retention Capacity: 90% initial capacity Recoverable Capacity: 95% initial capacity impedance: 60m Impedance Variation: ± 10 m Swelling: 0.1mm Appearance: No leakage, damage	Measured the high rate capacity as the initial capacity. Stored the recharged cells for 7 days at 60 ± 2 and then rest for 2 hrs at room temperature, standard discharged after checked the cells' appearance and impedance. Measured the high rate capacity as the initial capacity. Stored the recharged cells for 30 days at room temperature. Quickly discharged after checked the cells' appearance and impedance. Measured recoverable quickly discharge capacity and recoverable impedance.
7	Cycle Life (20)	Retention Capacity: 80% initial capacity Impedance: 120m Swelling: 0.50mm	Carry out 300 cycles (standard charge/ 1C discharge) at 20 ± 5 .



Shenzhen DTP Battery Co.,Ltd

Title	Polymer Lithium Ion Battery		
File No	523453-1050mAh	Ver 1.0	Page: 6/10

8. Safety Characteristics

No.	Items	Criteria	Test Conditions
1	Overcharge Characteristics	The maximum Temperature: 150 Appearance: No rupture, fire, smoke, nor leakage.	Charged the quickly discharged cells at 3C (3150mA) current with a voltage limit of 4.8V. Test can be terminated until constant voltage charge time is more than 8 hrs or charge current tapered less than 10mA.
2	Over-discharge Characteristics	The maximum Temperature: 150 Appearance: No rupture, fire, smoke, nor leakage.	Reverse charged the standard charged cells at 3C (3150mA) current to -10V or until the Cell voltage indicates a positive - V or discharge-time is more than 2.5 hrs.
3	Short-circuit Characteristics	The maximum Temperature: 150 Appearance: No rupture, fire, smoke, nor leakage.	Rest cells for 30min at 60 ± 2 after standard charged. Connect between Cell terminals with 1.5mm ² copper lead (electric resistance: 50m or less) and leave for 1 hour..
4	Hot Oven Characteristics	The maximum Temperature: 200 Appearance: No explode	The standard charged cell is to be heated in a gravity convection or circulating air oven. The temperature of the oven is to be raised at a rate of 5 ± 2 /min. The oven is to remain for 10 minutes at 130 ± 2 before the test is discontinued.
5	Impact Test	No fire, explode	After standard charged, the cell is to be placed on a flat surface. A 5/8inch (15.8mm) diameter bar is to be placed across the center of the sample. A 20 pound (9.1kg) weight is to be dropped from a height of 24±1 inch (610±25mm) onto the sample.
6	Crush Test	No fire, explode	After standard charged, the cell is to be crushed between two flat surfaces. The force for the crushing is to be applied by a hydraulic ram with a 1.25inch (32mm) diameter piston. The crushing is to be continue until a pressure reading of 2500 psig (17.2MPa) is reached on the hydraulic ram, applied force of 3000 pounds(13kN). Once the maximum pressure has been obtained it is to be released.



Shenzhen DTP Battery Co.,Ltd

Title	Polymer Lithium Ion Battery		
File No	523453-1050mAh	Ver 1.0	Page: 7/10

9. Reliability Characteristics

No.	Items	Criteria	Test Conditions
1	Static Humidity and Temperature Characteristics	Retention Capacity: 50% initial capacity Recoverable Capacity: 80% initial capacity Swelling: 1.5mm Impedance: 360m Appearance: No leakage, damage	Measured the high rate capacity as the initial capacity. Stored the recharged cells for 4 days at 60 ± 2 and 95%RH, then rest for 4 hrs at room temperature. Quickly discharged after checked the cells' appearance and impedance. Measured recoverable quickly discharge capacity and recoverable impedance.
2	Vibration Characteristics	OCV Variation: 0.01V Impedance: 180n Variation: 5 m Appearance: No deformation, leakage	Measured the initial OCV and impedance after standard charged at 20 ± 5 . Vibrate the cells for 30minutes on each direction at room temperature in 10min. Amplitude: 1.6mm, (p-p) Vibration: 10-60Hz (sweep 1 oct/min) Direction: X, Y, Z Then measure OCV and impedance.
3	70 Storage Characteristics	Recoverable Capacity: 30% initial capacity Swelling: 1.5mm Impedance: 360m Appearance: No leakage, damage	Measured the high rate capacity as the initial capacity. Stored the recharged cells for 48 hrs at 70 ± 2 , then rest for 2 hrs at room temperature. Quickly discharged after checked the cells' appearance and impedance. Measured recoverable quickly discharge capacity and recoverable impedance.

10. Protection Function

If a Polymer Li-ion Battery is subjected to a voltage higher than the allowable voltage or is charged with an excessive current, the electrolyte may decompose, resulting possibly in degassing or compromising cell safety. If cell voltage decreases below 1.0V approx., cell performance may deteriorate. Therefore, must be equipped protection circuit that can prevent overcharge, over-discharge, and over-current.

11. Guarantee Period of Quality

Guarantee period of quality is 6 months after sold.

12. Parameter of PCB

12.1 List of Parameter

Parameter	Symbol	Min	Typ.	Max.	Unit	Remark
10.1 Overcharge Detection Voltage	V _{cu}	4.255	4.3	4.35	V	



Shenzhen DTP Battery Co.,Ltd

Title	Polymer Lithium Ion Battery		
File No	523453-1050mAh	Ver 1.0	Page: 8/10

10.2	Overcharge Detection Delay Time	t_{cu}	0.15	1.2	4.6	S	
10.3	Release Voltage of Overcharge	V_{HC}	4.055	4.08	4.105	V	
10.4	Overdischarge Detection Voltage	V_{DL}	2.45	2.50	2.65	V	
10.5	Overdischarge Detection Delay Time	T_{DL}	36	144	290	ms	
10.6	Release Voltage of Overdischarge		3.05	3.00	2.95	V	
10.7	Over Current Defection	I_{CS}	0.5	1.1	4	A	
10.8	Over Current Detection Delay Time	T_{IOV}	4.5	9	18	ms	
10.9	Current Consumption in Normal	I_{OPE}	2	7	10	μA	$V_{D0}=3.5V, V_M=0V$
10.10	Current Consumption in Power Down	I_{PDN}				μA	
10.11	Impedance	R_{PCM}	30	70	100	m	

12.2 List of PCB BOM

Item	Reference	Description	Type	Qty	Mftr
1	U1	Protection IC	Dw01+	1	For tune
2	U2	Power Mosfet	8205	1	TSSOP-8
3	R1	Resistor	0603/470 / $\pm 5\%$	1	SKYWELL
4	R2	Resistor	0603/2K / $\pm 5\%$	1	SKYWELL
5	C1	Capacitor	0603/0.1uF/+80%-20%	2	SKYWELL
6		PCB	GG2030-AAA	1	ASSUN

12.3 Dimension of PCB

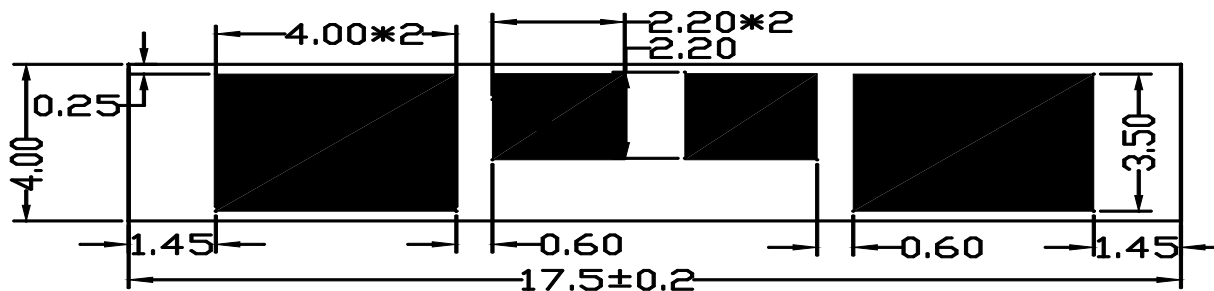

Thickness of the PCB: $0.60 \pm 0.10\text{mm}$

12.4 Circuit Diagram

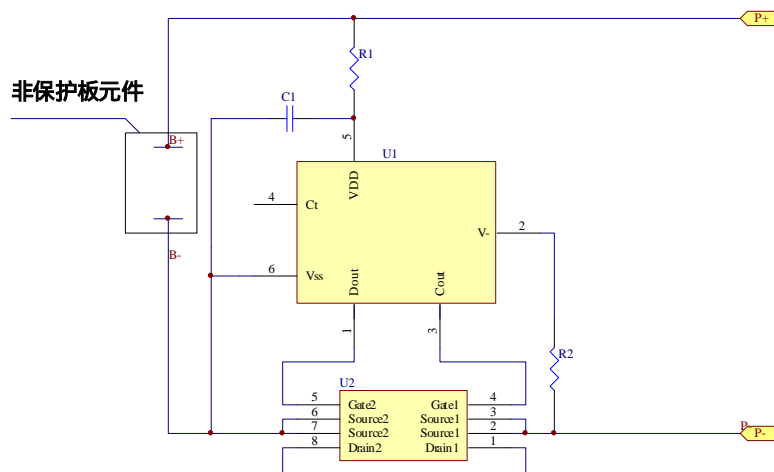



Shenzhen DTP Battery Co.,Ltd

Title

Polymer Lithium Ion Battery

File No

523453-1050mAh

Ver 1.0

Page: 9/10

13. Product Responsibility Agreement

Using cells must be observed Product Specification and remarks of shenzhen DTP battery Co., Ltd. Because misuse may cause cell heat, fire or explosive, DTP will not be responsible for any accident occurred by handling outside of the precautions in this specification.

14. Precaution Before Charging

Any information will be notified to consumer with data of quality and reliability while specification, materials, product process or control system will be changed.

15. Handling precautions on Lithium ion secondary cell

To assure product safety, describe the following precautions in the instruction manual of the equipment.

! Danger

- When charging the Cell, use dedicated chargers and follow the specified conditions.
- Use the Cell only in the specified equipment.
- Do not connect Cell directly to an electric outlet or cigarette lighter charger.
- Do not heat or throw Cell into a fire.
- Do not use, leave Cell close to fire or inside of a car where temperature may be above 60 . Also do not charge / discharge in such conditions.
- Do not immerse, throw, and wet Cell in water/ seawater
- Do not put batteries in your pockets or a bag together with metal objects such as necklaces. Hairpins, coins, or screws. Do not store batteries with such objects.
- Do not short circuit the (+) and (-) terminals with other metals.
- Do not place Cell in a device with the (+) and (-) in the wrong way around.
- Do not pierce Cell with a sharp object such as a needle.
- Do not hit with a hammer, step on or throw or drop to cause strong shock.
- Do not disassemble or modify the Cell.
- Do not solder a Cell directly.
- Do not use a Cell with serious scar or deformation.
- Thoroughly read the user's manual before use, inaccurate handling of lithium ion rechargeable Cell may cause leakage, heat, smoke, an explosion, or fire

! Warning

- Do not put Cell into a microware oven, dryer, or high-pressure container.
- Do not use Cell with dry cells and other primary batteries, or batteries of a different package, type, or brand.
- Stop charging the Cell if charging is not completed within the specified time.
- Stop using the Cell if abnormal heat, odor, discoloration, deformation or abnormal condition is detected during use, charge, or storage.



Shenzhen DTP Battery Co.,Ltd

Title	Polymer Lithium Ion Battery		
File No	523453-1050mAh	Ver 1.0	Page: 10/10

- Keep away from fire immediately when leakage or foul odor is detected.
- If liquid leaks onto your skin or clothes, wash well with fresh water immediately.
- If liquid leaking from the Cell gets into your eyes, do not rub your eyes. Wash them well with clean water and go to see a doctor immediately.

! Caution

- Store batteries out of reach of children so that they are not accidentally swallowed.
- If younger children use the Cell, their guardians should explain the proper handling.
- Before using the Cell, be sure to read the user's manual and cautions on handling thoroughly.
- Thoroughly read the user's manual for the charger before charging the Cell.
- For information on installing and removing from equipment, thoroughly read the user's manual for the specific equipment.
- Batteries have life cycles. If the time that the Cell powers equipment becomes much shorter than usual, the Cell life is at an end. Replace the Cell with a new same one.
- Remove a Cell whose life cycle has expired from equipment immediately.
- When not using Cell for an extended period, remove it from the equipment and store in a place with low humidity and low temperature.
- While the Cell pack is charged, used and stored, keep it away from objects or materials with static electric charges.
- If the terminals of the Cell become dirty, wipe with a dry clothe before using the Cell.
- The Cell can be used within the following temperature ranges. Do not exceed these ranges.

Charge temperature range : 0 to 45

Discharge temperature range : -20 to 60

(When using equipment)