

Customer/客户: \_\_\_\_\_

## Li-ion Polymer Battery Pack Specification

### 锂离子聚合物电池组合规格书

Pack Type: Cell+PCM+Connector Wire

 组合类型: 电芯+保护板+插头线

Battery Model: YJ 371030-77mAh

 电池型号: YJ 371030-77mAh

Typical Cell Capacity (mAh):

 典型电芯容量(mAh): 80

Customer Code:

 客户代码: PCL

Total Page:

 文件页数: 14

Prepared By/Date 编制/日期	Checked By/Date 审核/日期	Approved By/Date 批准/日期
HL	LQL	LP
2018-06-11	2018-06-11	2018-06-11

Customer Approval 客户承认	Signature/Date(签名/日期)
	Company Name(公司名称)
	Company Stamp(公司印章)

## Content

### 目录

1. Amendment Records 变更履历.....	3
2. Scope 适用范围.....	4
3. Initial Dimension 初始尺寸.....	4
4. Specification 产品规格.....	5
5. General Performance 常规性能.....	6
6. Environment Performance 环境性能.....	6
7. Mechanical characteristics and Safe Characteristic 安全性能和机械性能.....	6
8. Protection Circuit 保护电路.....	10
9. Warnings 警告.....	11
10. Cautions 注意.....	12
11. Notice for Designing Battery Pack 电池外壳设计注意事项.....	13
12. Handling of Battery 电池操作注意事项.....	13
13. Period of Warranty 保质期.....	14
14. Others 其它事项.....	14

**1. Amendment Records 变更履历****Product Amendment Records List**  
**产品变更履历表**

Edition 版本	Date 日期	Mark 标记	Amendment content 变更内容	Approved by 批准
A0	2018-06-11	/	NEW RELEASE	LP

## 2.Scope 适用范围

This specification describes the basic performance, technical requirement, testing method ,warning and caution of the Li-ion Polymer rechargeable battery pack, the pack defined in this documentation is an assembly which include battery, PCM ,wire etc,the specification only applies toYJ POWER GROUP LIMITED.

本标准规定了锂聚合物可充电电池的基本性能、技术要求、测试方法及注意事项，电池组合定义的是包括电芯，保护板和连接线等的组合，本标准只适用于深圳市言九电子科技有限公司所生产的锂聚合物电池。

## 3. Initial Dimension 初始尺寸

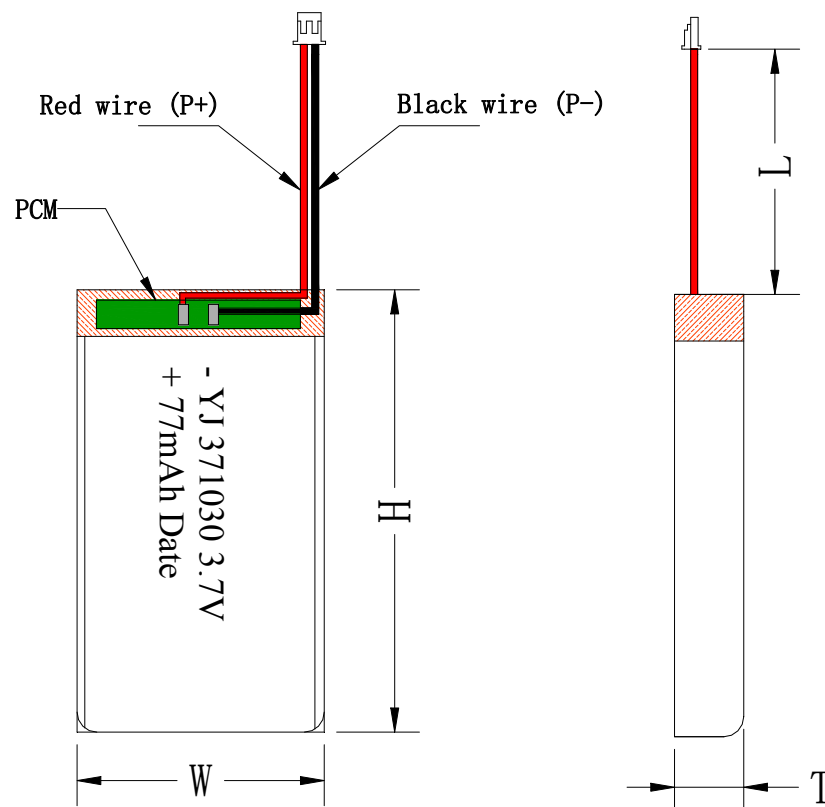

Remark:Date (日期随出货日期变化而变化)

Unit 单位 (mm)

T (厚度) Max	3.9 (Fresh)	W (宽度) Max	10.5	H(高度) Max	32.0
T <sub>1</sub> (厚度) Max	T*1.06 After cycle	L (长度)	50±3	L <sub>1</sub> (长度)	1.0~2.0
L <sub>2</sub> (长度)	/	Connector Wire (插头线)	51021-2P 正向 UL1571/ 28#		
PCM (保护板)	DW01+8205				

**4.Specification 产品规格**

NO.	Item 项目	Specifications 规格要求
4.1	Nominal capacity 标称容量	80mAh
	Minimum capacity 最小容量	77mAh
4.2	Initial Impedance 初始内阻	≤750mΩ
4.3	Battery Weight 电池重量	Approx(约): 1.6g
4.4	Nominal voltage 标称电压	3.7V
	Fully charge voltage(FC) 满充电电压 FC	4.2V
	Fully discharge voltage(FD) 满放电电压 FD	3.0V
4.5	Standard charge current 标准充电电流	0.5 C
4.6	Standard charging method 标准充电方法	0.5C CC ( constant current ) charge to FC, then CV(constant voltage FC)charge till charge current decline to ≤0.01C 0.5C CC (恒流) 充电至 FC, 再 CV (恒压 FC) 充电直至充电电流≤0.01C
4.7	Standard Charging time 标准充电时间	Approx 4 hours 大约 4 小时
	Fast Charging time 快速充电时间	Approx 3 hours 大约 3 小时 (1C Charge Current)
4.8	Max. charge current 最大充电电流	0°C~15°C 0.2C
		15°C~25°C 0.5C
		25°C~45°C 1C
4.9	Max. discharge current 最大放电电流	-10°C~15°C 0.2C
		15°C~60°C 1C
4.10	4.8 和 4.9 是电池常规使用的温度和最大电流,如需测试破坏性实验如外部短路,内部短路,热滥用则需按 7.7/7.8/7.9 要求执行	
4.11	Standard Discharge Current 标准放电电流	Constant current 0.2 C end voltage FD 持续电流: 0.2C 截止电压: FD
4.12	Charge cut-off voltage 充电截止电压	Ref. 8.1 VDET1
4.13	Discharge cut-off Voltage 放电截止电压	Ref. 8.1 VDET2
4.14	Storage temperature 储存温度	-20°C~60°C ≤1 month
		-20°C~45°C ≤3 month
		-20°C~25°C ≤1 year
4.15	Recoverable capacity 恢复容量	Constant current 0.5C charge to FC, then constant voltage FC charge to current declines to 0.01C, rest for 10min, constant current 0.2C discharge to FD, rest for 10min.Repeat above steps 3 times, recording the maximum capacity 先用 0.5 C 恒流充电至 FC, 再恒压 FC 充电直至充电电流≤0.01C,搁置 10 分钟,再用 0.2C 电流放电至 FD; 又搁置 10 分钟,重复以上步骤 3 次,记录容量最大值
4.16	Storage Humidity 储存湿度	≤75% RH
4.17	Appearance 外观	Without distortion and leakage 无变形、电解液泄露
4.18	Before shipment voltage 出货电压	≥3.8V
4.19	Standard testing condition 标准测试环境	Temperature(温度) : 23±2°C Humidity (湿度) : ≤75%RH Atmospheric Pressure (大气压) : 86-106 Kpa

Remark: 1.From 4.1 to 4.12, the testing condition is following 4.19 (standard testing condition)

从 4.1 至 4.12 项目, 测试环境遵从 4.19 (标准测试环境)

2.Operating temperature (使用温度) : charging(充电) 0°C~45°C ; Discharging (放电) : -10°C~60°C

If the working condition is out of 4.19, the performance will be some shift.

如果工作环境超出 4.19 范围, 性能将会有一些偏移。

### 5.General Performance 常规性能

No.	Item 项目	Test Methods and Condition 测试方法和条件	Criteria 标准
5.1	0.2C Capacity 0.2C 容量	At standard testing condition, After full charge with standard charge, rest 10min, then discharging at 0.2C to voltage FD, recording the discharging time. 在标准测试环境下, 标准充饱电后, 搁置 10 分钟, 然后用 0.2C 电流放电至 FD, 所记录放电时间	≥300min(分钟)
5.2	Cycle Life 循环寿命	At standard testing condition, constant current 0.5C charge to FC, then constant voltage charge to current declines to 0.01C, rest 10min, constant current 0.2C discharge to FD, rest 10min. Repeat above steps till continuously discharging capacity Higher than 70% of the Initial Capacities of the Cells 在标准测试环境下, 先用 0.5 C 恒流充电至 FC, 再恒压 FC 充电直至充电电流≤0.01C, 搁置 10 分钟, 再用 0.2C 电流放电至 FD; 又搁置 10 分钟, 重复以上步骤, 直到放电容量是初始容量的 70%	≥300 times(次)

### 6.Environment Performance 环境性能

No.	Item 项目	Test Methods and Condition 测试方法和条件	Criteria 标准
6.1	Leakage-Proof (漏液试验)	At standard testing condition, After full charge with standard charge, store at 55±2°C, 60±10%RH for 1 week. 标准充电条件下充满电后在温度 55±2°C, 相对湿度 60±10% 下储存一个星期	No leakage (visual inspection) (没有漏液/目测)
6.2	Capability of keeping electricity 荷电保持能力	At standard testing condition, After full charge with standard charge, no outer loading circuit, rest the pack 7days, discharging at 0.2C to voltage FD, recording the discharging time. 在标准测试环境下, 标准充饱电后, 无外接负载线路, 电池组合搁置 7 天, 然后用 0.2C 放电至 FD, 所记录放电时间。	≥285min (分钟)

### 7. Mechanical characteristics and Safe Characteristic 安全性能和机械性能

No.	Item 项目	Test Methods and Condition 测试方法和条件	Criteria 标准
7.1	Vibration Test 振动测试	At standard testing condition, After full charge with standard charge, fixed the cell to vibration table and subjected to vibration cycling that the frequency is to be varied at the rate of 1Hz per minute between 10Hz an 55Hz, the excursion of the vibration is 1.6mm. The cell shall be vibrated for 180 minutes per axis of XYZ axes. 将标准充电后的电芯固定在振动台上, 沿 X、Y、Z 三个方向各振动 60 分钟, 振幅 1.6mm, 振动频率为 10Hz~55Hz, 每分钟变化 1Hz。	No leakage 无泄漏 No fire 不起火 No explosion, 不爆炸

7.2	Free Drop 自由跌落	<p>At standard testing condition,After full charge with standard charge .The Battery is to be dropped from a height of 1 meter onto concrete ground.Fre drop one time respectively from X、Y、Z positive and negative axis(six Directions).</p> <p>将标准充电后的电芯从1米高度跌落至混凝土地面.从X、Y、Z正负六个方向各跌落一次。</p>	No leakage 无泄漏 No fire No explosion, 不起火, 不爆炸
7.3	Crush 挤压试验	<p>At standard testing condition, After standard charging, Crush between two flat plates. Applied force is about <math>13 \pm 0.2\text{kN}(1.72\text{Mpa})</math> ,Once the maximum force has been applied,the force is released.</p> <p>电池标准充电后, 电池放置在两块平面金属板间, 施加 <math>13 \pm 0.2\text{KN} 1.72\text{Mpa}</math> 的作用力, 一旦压力达到最大值即可停止试验。</p>	No fire 不起火 No explosion, 不爆炸
7.4	Short Circuit 常温短路试验 (20℃)	<p>At standard testing condition, After standard charging, Each test sample battery, in turn, is to be short-circuited by connecting the (+) and (-) terminals of the battery with a Cu wire having a maximum resistance load of <math>0.1 \Omega</math> .Tests are to be conducted at temperature <math>20 \pm 5^\circ\text{C}</math></p> <p>电池标准充电后, 在 <math>20 \pm 5^\circ\text{C}</math> 温度下依次把每个样品电池的正负极用铜线连接起来使电池外部短路--线路总电阻不超过 <math>0.1 \Omega</math> )</p>	No fire 不起火 No explosion, 不爆炸
7.5	Short Circuit 高温短路试验 (55℃)	<p>At standard testing condition, After standard charging, Each test sample battery, in turn, is to be short-circuited by connecting the (+) and (-) terminals of the battery with a Cu wire having a maximum resistance load of <math>0.1 \Omega</math> .Tests are to be conducted at temperature <math>60 \pm 5^\circ\text{C}</math> .</p> <p>在 <math>55 \pm 5^\circ\text{C}</math> 温度下依次把每个样品电池的正负极用铜线连接起来使电池外部短路--线路总电阻不超过 <math>0.1 \Omega</math> )</p>	No fire 不起火 No explosion, 不爆炸
7.6	Impact 冲击试验	<p>At standard testing condition, After standard charging, A 56mm diameter bar is inlayed into the bottom of a 10kg weight. And the weight is to be dropped from a height of 1m onto a sample battery and then the bar will be across the center of the sample. (用一条直径为 56mm 的圆棒放置在电池中央, 将一 10Kg 的重锤从 1m 的高度垂直落下在电池的中心位置)</p>	No fire 不起火 No explosion, 不爆炸
7.7	External short circuit 外部短路	<p>1. The battery should be in <math>20^\circ\text{C} \pm 5^\circ\text{C}</math> environment temperature constant at 0.2 C discharge exile to terminate with specified electrical voltage of 3.0 V.</p> <p>2. Charge: according to <math>45^\circ\text{C}</math> high temperature and low temperature <math>10^\circ\text{C}</math> respectively, in the high or low temperature environment let stand 1-4 hours, according to the charging 0.2 C to 4.25 V, until the charging current is reduced to 0.05 C. Remove the battery after charging temperature let stand</p>	No fire 不起火 No explosion, 不爆炸

		<p>for 1-2 hours.</p> <p>3. External short circuit test: use an external resistor of <math>80\text{m}\Omega \pm 20\text{m}\Omega</math> wire connected to the batteries extreme external short circuit, plus or minus in the test cell can maintain 24 hours or external temperature down to the most high temperature rise 20%, meet the one,</p> <p>1. 电池应在 <math>20^{\circ}\text{C} \pm 5^{\circ}\text{C}</math> 的环境温度下以 0.2C 放电恒流放电至规定的终止电压 3.0V.</p> <p>2. 充电: 分别按高温 <math>45^{\circ}\text{C}</math> 和低温 <math>10^{\circ}\text{C}</math> 充电, 在高温或低温环境中静置 1-4 小时, 按 0.2C 充电至 4.25V, 直到充电电流减少到 0.05C 止. 充电完成后取出电池常温静置 1-2 小时.</p> <p>3. 外部短路测试: 用一外部电阻 <math>80\text{m}\Omega \pm 20\text{m}\Omega</math> 的导线连接电芯的正负极端使其外部短路, 在试验中的电芯能维持 24 小时或外部温度下降到最高温升值的 20%, 满足其一即可,</p>	
7.8	Internal short circuit 内部短路	<p>1. The battery should be in <math>20^{\circ}\text{C} \pm 5^{\circ}\text{C}</math> environment temperature constant at 0.2 C discharge exile to terminate with specified electrical voltage of 3.0 V.</p> <p>2. Charge: according to <math>45^{\circ}\text{C}</math> high temperature and low temperature <math>10^{\circ}\text{C}</math> respectively, in the high or low temperature environment let stand 1-4 hours, according to the charging 0.2 C to 4.25 V, until the charging current is reduced to 0.05 C. Remove the battery after charging temperature let stand for 1-2 hours.</p> <p>3. Disassemble the battery and place the core of the nickel particle in the aluminum foil bag and then put it in the specified high temperature or low temperature box for 45 + 5 minutes.</p> <p>4. Remove batteries from the sealed packaging, batteries voltage detection terminal and monitoring the surface temperature of thermocouple, put the batteries in extrusion equipment, placed the position of nickel particles on pressure head directly.</p> <p>3. Bottom surface of moving part of the press equipment is made of Nitrile rubber of Acryl. which is put on the <math>10\text{mm} \times 10\text{mm}</math> stainless steel shaft. Nitrile rubber bottom surface is for cylindrical cell test. For prismatic test <math>5\text{mm} \times 5\text{mm}</math> (2mm thickness) Acryl is put on the Nitrile rubber. The fixture is moved down at the speed of 0.1mm/S monitoring the cell voltage. when voltage drop caused by the internal short-circuit is detected, stop descent immediately and keep pressing jig in the position for 30S and then release the pressure. Volgtage is monitored more than 100 times per second and if voltage is dropped more</p>	No fire 不起火 No explosion, 不爆炸



		<p>than 50 mV compare to the initial voltage, it is defined to internal short circuit has occurred. if the pressure reaches 800N for cylindrical cell and 400N for prismatic cell, stop descent immediately and then keep in the position.</p> <p>1. 电池应在 20℃ ± 5℃ 的环境温度下以 0.2C 放电恒流放电至规定的终止电压 3.0V.</p> <p>2. 充电: 分别按高温 45℃ 和低温 10℃ 充电, 在高温或低温环境中静置 1-4 小时, 按 0.2C 充电至 4.25V, 直到充电电流减少到 0.05C 止. 充电完成后取出电池常温静置 1-2 小时.</p> <p>3. 拆解电池, 把装有镍颗粒的电芯放在铝箔袋中, 之后放入规定的高温或低温箱中 45 ± 5 分钟.</p> <p>4. 将电芯从密封包装中取出, 附上电压检测的端子和监测电芯表面温度的热电偶, 把电芯放在挤压设备下, 放置镍颗粒的位置对准压头正下方.</p> <p>5. 内部短路. 挤压设备的压头表面由丁腈橡胶或压克力制成, 并固定在 10mm*10mm 的不锈钢轴上, 圆柱形电芯测试用丁腈橡胶表面, 菱形电芯的测试用丁腈橡胶表面再固定 2mm 厚 5mm*5mm 的压克力, 压轴以 0.1mm/S 的速度下压, 同时监测被测电芯电压, 当内部短路造成电芯电压下降, 立即停止下压并保持压轴静止 30S 之后, 释放压力, 下压的同时, 以 100 次/S 的速度扫描电芯电压, 当电芯电压比初始电压降低 50mV, 判定为内部短路已发生. 如果对圆柱形电芯的压力达到 800N 或对菱形电芯的压力达到 400N, 停止下压并保持。</p>	
7.9	Thermal abuse 热滥用	<p>1. The battery should be in 20 °C ± 5 °C environment temperature constant at 0.2 C discharge exile to terminate with specified electrical voltage of 3.0 V.</p> <p>2. Charge: according to 45 °C high temperature and low temperature 10 °C respectively, in the high or low temperature environment let stand 1-4 hours, according to the charging 0.2 C to 4.25 V, until the charging current is reduced to 0.05 C. Remove the battery after charging temperature let stand for 1-2 hours.</p> <p>3. Place the batteries in a gravity or circulating air convection oven, oven temperature by 5 °C / min plus or minus 2 °C / min speed up to 130 °C + 2 °C, the battery needs to be placed in this environment for 10 min (large batteries need 30 min), the termination</p> <p>1. 电池应在 20℃ ± 5℃ 的环境温度下以 0.2C 放电恒流放电至规定的终止电压 3.0V.</p> <p>2. 充电: 分别按高温 45℃ 和低温 10℃ 充电, 在高温或低温环境中静置 1-4 小时, 按 0.2C 充电至 4.25V, 直到充电电流减少到 0.05C 止. 充电完成后取出电池常温静置 1-2 小时.</p> <p>3. 将电芯放置在一个有引力或循环空气对流的烘箱中, 烘</p>	No fire 不起火 No explosion, 不爆炸

箱的温度以  $5^{\circ}\text{C}/\text{min} \pm 2^{\circ}\text{C}/\text{min}$  速度升至  $130^{\circ}\text{C} \pm 2^{\circ}\text{C}$ ，电池需要放置在此环境中 10min（大电芯需要 30min），试验终止

※ Above testing of safe characteristic must be with protective equipment.(安全性能测试应在有保护措施下进行)

## 8. Protection Circuit 保护电路

### 8.1 PCM Standard

Item (项目)	Symbol (符号)	Content (详细内容)	Criterion (标准)
Over charge Protection (过充保护)	VDET1	Over charge detection voltage (过充电检测电压)	$4.28 \pm 0.05\text{V}$
	tVDET1	Over charge detection delay time (过充电检测延迟时间)	80~200ms
	VREL1	Over charge release voltage (过充电解除电压)	$4.10 \pm 0.05\text{V}$
Over discharge protection (过放保护)	VDET2	Over discharge detection voltage (过放电检测电压)	$2.40 \pm 0.1\text{V}$
	tVDET2	Over discharge detection delay time (过放电检测延迟时间)	40~120ms
	VREL2	Over discharge release voltage (过放解除电压)	$3.0 \pm 0.1\text{V}$
	IDP	Over current detection current (过电流保护电流)	1.3~4A
	tVDET3	Detection delay time (检测延迟时间)	5-20ms
			Release condition (保护解除条件)
Short protection (短路保护)		Detection condition (保护条件)	Exterior short circuit (外部电路短路)
	TSHORT	Detection delay time (检测延迟时间)	50~120uS
		Release condition (保护解除条件)	Cut short circuit (断开短路电路)
Interior resistance (内阻)	RDS	Main loop electrify resistance (主回路通态电阻)	$\text{VC}=4.2\text{V}, \text{RDS} \leq 70\text{m}\Omega$
Current consumption (消耗电流)	IDD	Current consume in normal operation (工作时电路内部消耗)	$4.0\mu\text{A}$ Type $7.0\mu\text{A}$ Max

## 8.2 BOM For PCM 保护板物料清单

NO.	Location 元件编号	Part name 元件名称	Specification 元件规格	Packtype 封装形式	Q'ty 数量	Maker 厂商
1	U1	Protection IC	DW01	SOT-23-6	1	
2	U2	MOSFET	8205	SOT-23-6	1	
3	R1	Resistance	100 Ω ± 5%	0402	1	
4	R2	Resistance	1K Ω ± 5%	0402	1	
5	C1	Capacitance	0.1 μ F	0402	1	
6	PCB	Print circuit board	/	/	1	

## 8.3 Schematic diagram 原理图

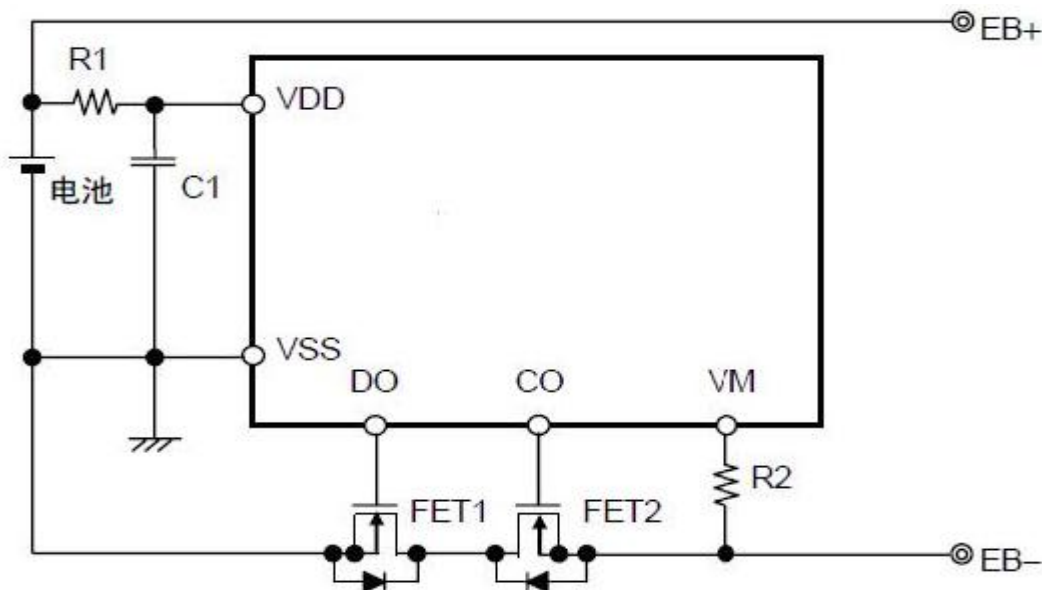

## 9. Warnings 警告

Load circuit may cause voltage and current, and the voltage or current may add to pack, the voltage or current must be controlled as lower than RWV and RWI, larger voltage or current may damage the PCM of pack.

☆负载可能产生电压和电流,该电压和电流会反加在电池组合(含PCM)上,该电压和电流不能超过保护板自身反向耐压耐流值,过高电压或电流会损坏电池组合中的保护板。

To prevent the possibility of the pack from leaking, heating, fire .please observe the following precautions:

☆为防止电池组合可能发生的泄漏,发热,起火,请注意以下预防措施:

The soft aluminum packing foil is very easily damaged by sharp edge parts such as Ni-tabs, pins and needles .Do not strike at pack with any sharp edge parts.

☆ 电池组合外包装膜易被镍片,尖针等尖锐部件损伤,禁止用尖锐部件碰伤电池。

Do not immerse the pack in water and seawater

☆ 严禁将电池组合浸入海水或水中。

Do not use and leave the pack near a heat source as fire or heater

☆ 禁止将电池组合在热高温源旁,如火,加热器等使用设备。

When recharging, use the battery charger specifically for that purpose

☆ 充电时请选用锂离子电池专用充电器.

Do not reverse the positive and negative terminals

☆ 禁止颠倒正负极使用电池组合

Do not connect the pack to an electrical outlet

☆ 禁止将电池组合直接接入电源插座

Do not discard the pack in fire or heat it

☆ 禁止将电池组合丢入火或加热器中

Do not short-circuit the pack by directly connecting the positive and negative terminal with metal object such as wire

☆ 禁止用金属直接将电池组合的正负极进行短路连接.

Do not transport and store the battery together with metal objects such as necklaces, hairpins etc.

☆ 禁止将电池组合与金属,如发夹,项链等一起运输或贮存.

Do not strike or throw the pack.

☆ 禁止敲击或抛掷,踩踏电池组合等.

Do not directly solder the pack or battery and pierce the battery with a nail or other sharp object.

☆ 禁止直接焊接电池组合或电芯,禁止用钉子或其它利器刺穿电池组合或电芯.

## 10. Cautions 注意

Do not use or leave the pack at very high temperature (for example, at strong direct sunlight or a vehicle in extremely hot conditions). Otherwise, it can overheat or fire or its performance will be degenerate and its service life will be decreased.

△ 禁止在高温下(直热的阳光下或很热的汽车中)使用或放置电池组合,否则可能会引起电池过热,起火或功能失效,从而导致电池组合寿命减短.

Do not use it in a location where static electricity is great, otherwise, the safety devices in the pack may be damaged, which will cause hidden trouble of safety.

△ 禁止在强静电和强磁场的地方使用,否则易破坏电池组合的安全保护装置,带来不安全隐患.

If the pack leaks and the electrolyte get into the eyes, do not rub eyes, instead, rinse the eyes, with clean running water, and immediately seek medical attention. Otherwise, eye injury can result.

△ 如果电池发生泄漏,电解液进入眼睛,请不要揉擦,应用清水冲洗眼睛,并立即送医院治疗,否则会伤害眼睛.

If the pack takes off an odor, generates heat, becomes discolored or deformed, or in any way appear abnormal during use, recharging or storage, immediately remove it from the device or battery charge and stop using it.

△ 如果电池组合在使用或贮存中发出异味,发热,变色,变形,或者是在充电过程中出现任何异常现象,立即将电池从充电器或装置中移开,并停止使用.

In case the pack terminals are dirt, clean the terminals with a dry cloth before use. Otherwise power failure or charge failure may occur due to the poor connection with the instrument.

△ 如果电池组合的连接点弄脏,使用前应用干布抹净,否则可能会因接触不良而影响性能失效.

Be aware discharged battery may cause fire or smoke, tape the terminals to insulate them.

△ 废弃之电池应用绝缘纸包住电极,以防起火,冒烟.

The pack should be stored at room temperature, charged to about 40% to 60% of capacity. In case of over-discharge, pack should be charged for one time every 3 months while storing and batteries should be discharge and charge after being stored more than a year in order to activate it and restore energy.

△ 电池组合应当在室温下存放,应充到 40%至 60%的电量。为防止电池过放,建议每 3 个月进行一次充电,如储存时间超过一年,建议每年进行一次充、放电以激活电池。

## 11. Notice for Designing Battery Pack 电池外壳设计注意事项

### 11.1 Pack toughness (外壳坚韧度)

Battery pack should have sufficient strength and the LIP cell inside should be protected from mechanical shocks.

电池外壳应该有足够的机械强度使聚合物电池免受机械撞击。

### 11.2 Cell fixing (电池的固定)

The LIP cell should be fixed to the battery pack by its large surface area.

No cell movement in the battery pack should be allowed.

电池最大面积的一面应该固定在外壳上,安装后电池不能有松动。

### 11.3 Inside design (外壳内部设计)

No sharp edge components should be insides the pack containing the LIP cell.

外壳内安装电池的部位不应有锋锐边。

### 11.4 Tab connection (极片连接)

Ultrasonic welding or spot welding is recommended for LIP tab connection method.

Battery pack should be designed that shear force are not applied to the LIP tabs.

If apply manual solder method to connect tab with PCM, below notice is very important to ensure battery performance:

- The solder iron should be temperature controlled and ESD safe;
- Soldering temperature should not exceed 350°C;
- Soldering time should not be longer than 3s;
- Soldering times should not exceed 5 times, Keep battery tab cold down before next time soldering;
- Directly heat cell body is strictly prohibited, Battery may be damaged by heat above approx. 100°C

建议使用超声波或点焊焊接方法;外壳设计应使极片不受外力。

如果使用人工焊接保护板,下面的注意事项对于确保电池性能非常重要:

- 焊接烙铁的温度必须可控且可防静电;
- 焊接时烙铁的温度不能超过 350°C;
- 焊锡时间不能超过 3 秒钟;
- 焊锡次数不能超过 5 次,待极片冷却后才能进行下一次焊锡;
- 严禁直接加热电芯,高于 100°C 度会损害电芯。

## 12. Handling of Battery 电池操作注意事项

### 1 .Soft Aluminum foil (铝箔软包装)

Easily damaged by sharp edge parts such as pins and needles, Ni-tabs, comparing with metal-can-cased LIB.

相对于金属壳的方形电池，铝箔软包装比较容易被锐利部件刺损，如针尖、镍带。

△Don't strike battery with any sharp edge parts 勿用尖锐处撞击电池。

△Trim your nail or wear glove before taking battery 剪掉指甲，或者戴手套。

△Clean worktable to make sure no any sharp particle 清理工作台，避免尖锐零部件。

2. Sealed edge may be damaged by heat above 100°C, bend or fold sealed edge.

封边被加热到 100°C 以上以及弯折封边都容易使封边受损。

3. Prohibition short circuit (禁止电池短路)

Never make short pack circuit. It generates very high current which causes heating of the cells and may cause electrolyte leakage, gassing or explosion that are very dangerous. The LIP tabs may be easily short-circuited by putting them on conductive surface. Such outer short circuit may lead to heat generation and damage of the cell.

避免电池短路。短路会产生很高的电流而使电池发热以及电解液泄漏，产生气体或爆炸是非常危险的。极片连接在导电物体表面很容易短路，外部短路会导致发热及损害电池。

4. Mechanical shock (机械撞击)

△LIP cells have less mechanical endurance than metal-can-cased LIB.

△Falling, hitting, bending, etc. may cause degradation of LIP characteristics.

聚合物电池比金属壳方形电池的机械耐久性更小。

跌落、碰撞、弯曲等等都可能会降低聚合物电池的性能。

### 13. Period of Warranty 保质期

The period of warranty is one year from the date of shipment. YJ Power guarantees to give a replacement in case of battery with defects proven due to manufacturing process instead of the customer abuse and misuse.

电池的保质期从出货之日算起为一年。如果证明电池的缺陷是在我们公司制造过程中造成的而不是客户滥用或错误使用造成，本公司负责退换电池。

### 14. Others 其它事项

1. The customer is requested to contact YJ Power in advance, if and when the customer needs other applications or operating conditions than those described in this document. Additional experimentation may be required to verify performance and safety under such conditions.

客户若需要将电池用于超出文件规定以外的应用，或在文件规定以外的使用条件下使用电池，应事先联系言九能源，因为需要进行特定的实验测试以核实电池在该使用条件下的性能及安全性。

2. YJ Power will take no responsibility for any accident when the battery is used under other conditions than those described in this Document.

对于在超出文件规定以外的条件下使用电池而造成的任何意外事故，言九能源概不负责。

3. YJ Power will inform, in a written form, the customer of improvement(s) regarding proper use and handing of the battery, if it is deemed necessary.

如有必要，言九能源会以书面形式告之客户有关正确操作使用电池的改进措施。

4. Any matters that this specification does not cover should be conferred between the customer and YJ Power.

任何本说明书中未提及的事项，须经双方协商确定。