



Product Specifications

File No: E-SPE-0135-01

Ver: 00

Page: 1/10

Date: 2017-02-15

Product Specifications

Type : Polymer Li-ion Rechargeable Battery

Model : DTP 502535

Specification : 3.7V/400mAh

Prepared By/Date	Checked By/Date	Approved By/Date
Panda Nie 2017/02/15		

Customer confirmation:

Sign/Date:



Product Specifications

File.No: E-SPE-0135-01

Ver: 00

Page: 2 / 10

Date: 2017-02-15

Revise the history

Revision Num	Date	Revise the items
01	2017-02-15	Publishes for the first time-----



Product Specifications

File.No: E-SPE-0135-01
Ver: 00
Page: 3 / 10
Date: 2017-02-15

Contents

1	Scope	4
2	Product Type and Product Model	4
2.1	Type.....	4
2.2	Model.....	4
3	Basic Product Characteristics	4
3.1	Rated Capacity	4
3.2	Minimum Capacity.....	4
3.3	Nominal Voltage	4
3.4	Charge Limited Voltage.....	4
3.5	Discharge Cut-off Voltage.....	4
3.6	End-of-charge Current.....	4
3.7	Standard Charge.....	4
3.8	Standard Discharge	4
3.9	Maximum Continuous Charge Current	4
3.10	Maximum Continuous Discharge Current.....	4
3.11	Operating And Storage Temperature Range	4
3.12	Operating And Storage Humidity Range.....	4
3.13	Weight.....	4
4	External Dimension.....	4
5	Outside Appearance.....	5
6	Basic Electrical Characteristics.....	5
6.1	Open Circuit Voltage.....	5
6.2	Internal Impedance	5
6.3	Rated Capacity (0.2C ₅ A).....	5
6.4	1C ₅ A Capacity.....	5
6.5	Temperature Characteristics.....	5
6.6	Storage Characteristics.....	5
6.7	Cycle Life (20°C)	5
7	Safety Characteristics	5
7.1	Overcharge Characteristics	5
7.2	Over-discharge Characteristics.....	6
7.3	Short-circuit Characteristics.....	6
7.4	Hot Oven Characteristics.....	6
7.5	Heavy Collision.....	6
8	Reliability Characteristics	6
8.1	Static Humidity and Temperature Characteristics.....	6
8.2	Vibration Characteristics	6
8.3	Bump Characteristics	7
8.4	Free Drop Characteristics.....	7
9	Assembling Request.....	7
9.1	List of Parameter.....	7
9.2	Parts list.....	7
9.3	Application Circuit.....	7
9.4	Maps.....	8
9.5	External Dimension Drawing.....	9
10	Guarantee Period of Quality.....	9
11	Matters needing attention.....	9
12	Statement.....	10



Product Specifications

File.No: E-SPE-0135-01
 Ver: 00
 Page: 4 / 10
 Date: 2017-02-15

1. Scope

This specification shall be applied to the batteries from Data Power Technology Limited's product.

2. Product Type and Product Model

2.1 Type: Polymer Li-ion Recharged Battery

2.2 Model: DTP 502535

3. Product Basic Characteristics

No	Item	Characteristics
3.1	Rated Capacity	400mAh
3.2	Minimum Capacity	400mAh
3.3	Nominal Voltage	3.70V
3.4	Charge Limited Voltage	4.20V
3.5	Discharge Cut-off Voltage	2.75V
3.6	End-of-charge Current	0.01C
3.7	Standard Charge	Charge with 0.2C(80mA) up to Limited Voltage , Charge with limited Voltage up to end-of-charge current.
3.8	Standard Discharge	Using 0.2C(80mA) constant current discharge to the Discharge Cut-off Voltage.
3.9	Maximum Continuous Charge Current	0.5C (200mAh)
3.10	Maximum Continuous Discharge Current	0.5C (200mAh)
3.11	Operating Temperature Range	Charge 10 ~ 45°C
		Discharge - 20 ~ 60°C
	Storage Temperature Range	-20 ~ 60°C
3.12	Operating And Storage Humidity Range	65 ± 20% RH
3.13	Weight	Less than 11 g

4. Cell Dimension

Item	Dimension (mm)
T	Max 5.0
W	Max 25.0
L	Max34.5
L1	Max31.0
L2	Ma35.0
L3	6.5±0.5
M	13.0±1.0
N	3.0±0.1

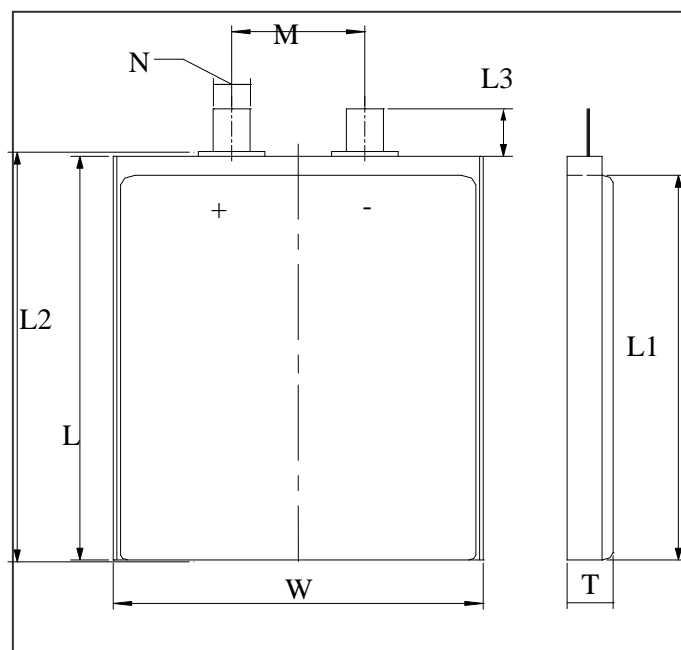



Product Specifications

File.No: E-SPE-0135-01
 Ver: 00
 Page: 5 / 10
 Date: 2017-02-15

5. Appearance

It shall be free from any defects such as remarkable scratches, breaks, cracks, discoloration, leakage, or middle deformation

6. Basic Electrical Characteristics

No.	Items	Criteria	Test Method
6.1	Open Circuit Voltage	3.75V~3.95V	Measure with voltmeter.
6.2	Internal Impedance	$\leq 200\text{m}\Omega$	Measure cells using an alternate current impedance meter at 1kHz .
6.3	Rated Capacity (0.2C ₅ A)	$\geq 400\text{mAh}$	Discharged after the standard charged cells rest 10min at 23±2°C , Test can be discontinued when more than Rated capacity. Three cycles are permitted..
6.4	1C ₅ A discharge capacity	$\geq 400\text{mAh} \times 90\%$	Discharged after the standard charged cells rest 10min at 23±2°C , Test can be discontinued when more than 90% *rated capacity. Three cycles are permitted.
6.5	Temperature Characteristics	1. Appearance: No deformation、ruptures nor leakage. 2.Discharge Capacity: 55°C: $\geq 85\% \times$ initial capacity; -10°C: $\geq 60\% \times$ initial capacity	Measured the 0.2C ₅ A capacity at 23±2°C as the initial capacity. Stored the rechargeable batteries for 16-20hrs at -10 ± 2°C ; 2h for 55 ± 2°C, and then 0.2C ₅ A discharged at this temperature, Checked the batteries' appearance after rest for 2 hrs at room temperature.
6.6	Storage Characteristics	Retention Capacity: $\geq 85\% \times$ initial capacity	Measured the 0.2C ₅ A capacity at (20±5)°C as the initial capacity. Stored the recharged cells for 6 days at 20 ± 5°C and then rest for 2 hrs at room temperature, 0.2C ₅ A discharged after checked the cells' appearance.
6.7	Cycle Life (20°C)	Capacity \geq initial capacity × 80%	0.2C discharged after 0.2C ₅ A full charges at 20± 5°C. Carry out 300 cycles

Remark 1 Standard charge: 0.2C₅A charge up to charge limited voltage at (20±5)°C. Charge with limited voltage up to end of current. It is the same to the next content

7. Safety Characteristics

No.	Items	Criteria	Test Method
7.1	Overcharge Characteristics	Appearance: No rupture, fire, smoke, nor leakage.	When the battery is fully charged, go on loading for 8h with a twice rating voltage, 2.0C ₅ A out put current, it starts the over charge protection function.



Product Specifications

File.No: E-SPE-0135-01
 Ver: 00
 Page: 6 / 10
 Date: 2017-02-15

7.2	Over-discharge Characteristics	Appearance: No rupture, fire, smoke, nor leakage.	The battery is discharged at 0.2C5A in the constant current till it reaches over discharge protection voltage at (20±5) °C, connected with a 30Ω lead and discharged for 24h
7.3	Short-circuit Characteristics	OCV ≥3.6V; Appearance: No rupture, fire, smoke, nor leakage.	As the battery has completed charging, short circuit the positive and negative contacts with 0.1Ω resistor for 1h for appearance check, then disconnect the resistor between the contacts, the battery shall be charged at 1.0C5A mA in the constant current for 5S
7.4	Hot Oven Characteristics	Appearance: No explode. No fire.	The battery is to be heated in a gravity convection or circulating air oven after standard charged at 23±2°C, The temperature of the oven is to be raised at a rate of 5±2°C /min. The oven is to remain for 30 minutes at 400±2°C before the test is discontinued.
7.5	Heavy Collision	Appearance: No explode. No fire.	Putting the battery on the platform, using 10KG heavy hammer free drop from 1M height onto the fixed battery.

Remark 2 All safety characteristics are carried out by specialized personnel familiar with Li-ion knowledge or under instruction of our technical personnel after detailed consultation.

8. Reliability Characteristics

No.	Items	Criteria	Test Method
8.1	Static Humidity and Temperature Characteristics	Retention Capacity: ≥60%× initial capacity Appearance: No leakage, damage, smoke, rupture.	Measured the 1C5A capacity at 23±2°C as the initial capacity. Stored the rechargeable batteries for 2 days at 40 ± 2°C and 90%-95%RH, then rest for 2 hrs at room temperature. 0.2C5A discharged after checked the batteries appearance. Measured recoverable 1C5A discharge capacity with 3 cycles..
8.2	Vibration Characteristics	OCV ≥3.6V; Appearance: No fire, leakage, explode, rupture	After fully charging, fixing the battery onto the vibration platform. with amplitude 0.38mm circularly scanning vibrating in the frequency of 10HZ-55HZ from three directions X、Y、Z for 30min respectively in its scanning frequency velocity 10CT/min.



Product Specifications

File.No: E-SPE-0135-01
 Ver: 00
 Page: 7/10
 Date: 2017-02-15

8.3	Bump Characteristics	OCV $\geq 3.6V$; Appearance: No fire, leakage, explode, rupture	After vibration testing, use a clip or directly fix the battery on to the platform in the direction of X、Y、Z vertical complementary axis, then adjust its acceleration and pulse duration as below to have a bump test. Pulse peak acceleration 100m/s ² . Bumps per minute 40-80. Pulse duration 16ms. Bump times 1000 \pm 10.
8.4	Free Drop Characteristics	Retention Capacity: $\geq 85\%$ \times nominal capacity. Appearance: No fire, leakage, explode, rupture	After bump testing, the battery shall be immediately dropped from the height of 1000mm (minimum height) onto a 18mm~20mm hard board on the cement floor. Free drop one time respectively from X、Y、Z positive and negative axis(six directions). After that, the battery is discharged at 1C5A to its final voltage.

9. Assembling Request

9.1 List of Parameter

Item	Symbol	Content	Criterion
Over charge Protection	V_{DET1}	Over charge detection voltage	4.300V \pm 0.050V
	tV_{DET1}	Over charge detection delay time	80 ms
	V_{REL1}	Over charge release voltage	4.100 \pm 0.050V
Over discharge protection	V_{DET2}	Over discharge detection voltage	2.4V \pm 0.100V
	tV_{DET2}	Over discharge detection delay time	20ms
	V_{REL2}	Over discharge release voltage	3.0V \pm 0.100V
Over current protection	V_{DET3}	Over current detection voltage	0.150 \pm 0.030V
	I_{DP}	Over current detection current	2.5~4.5A
	tV_{DET3}	Detection delay time	10ms
		Release condition	Cut load
Short protection		Detection condition	Exterior short circuit
	T_{SHORT}	Detection delay time	$\leq 5\mu s$
		Release condition	Cut short circuit
Interior resistance	R_{DS}	Main loop electrify resistance	VC=3.6V; $R_{DS} \leq 60m\Omega$

9.2 Parts list

NO.	Location	Part name	Specification	Pack type	Q' ty	Maker/Remark
1	U1	Battery protection IC	DW01+	SOT23-6	1	Frotune
2	U2	Silicon MOSFET	8205	SOT-6	1	Cansen
3	R1	Resistance	SMD 100 $\Omega \pm 5\%$	0603	1	YAGEO
4	R2	Resistance	SMD 1K $\Omega \pm 5\%$	0603	1	YAGEO
5	C1	Capacitance	SMD 0.1 μF	0603	1	TDK
6	PCB	Print circuit board			1	



Product Specifications

File.No: E-SPE-0135-01
Ver: 00
Page: 8 / 10
Date: 2017-02-15

9.3 Application Circuit

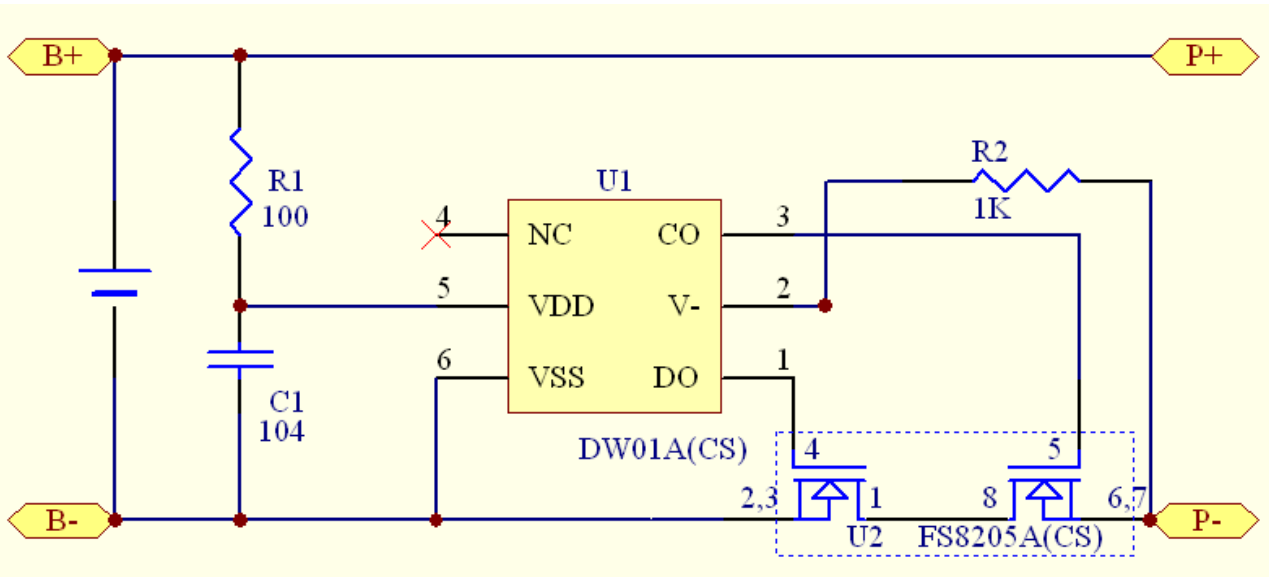

9.4 Maps

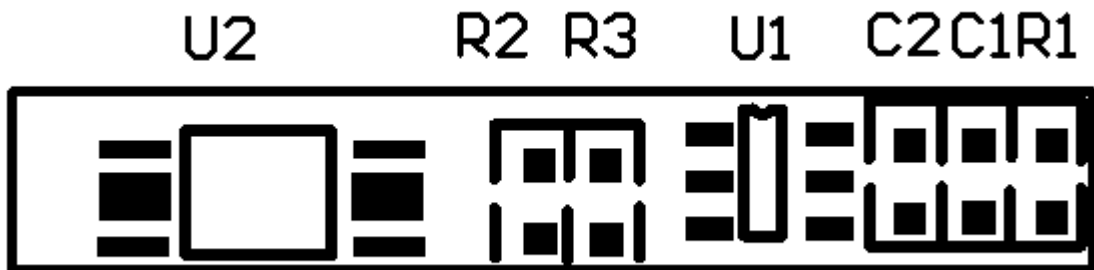

9.5 External Dimension Drawing

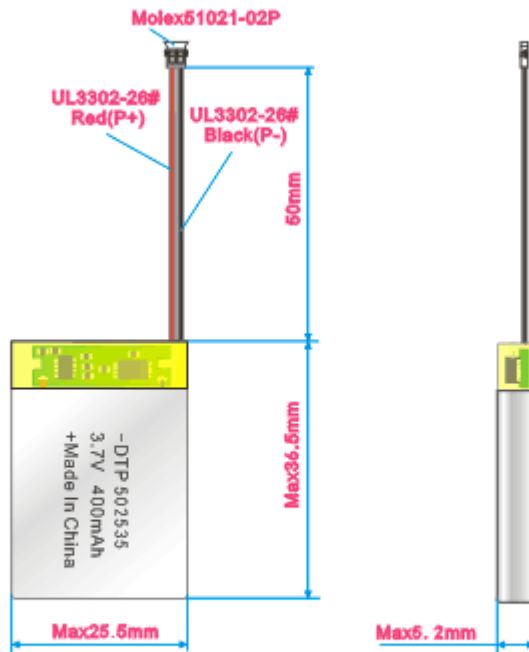

10. Guarantee Period of Quality

Guarantee period of quality is 12 months after sold.

11. Matters needing attention

Strictly observes the following needing attention. Data Power will not be responsible for any accident occurred by handling outside of the precautions in this specification.

! Danger

- Strictly prohibits heat or throw cell into fire.
- Strictly prohibits throw and wet cell in liquid such as water、 gasoline or drink etc.
- Strictly prohibits use leave cell close to fire or inside of a car where temperature may be above 60°C. Also do not charge / discharge in such conditions.
- Strictly prohibits put batteries in your pockets or a bag together with metal objects such as necklaces. Hairpins, coins, or screws. Do not store or transportation batteries with such objects.
- Strictly prohibits short circuit the (+) and (-) terminals with other metals.
- Do not place Cell in a device with the (+) and (-) in the wrong way around.
- Strictly prohibits pierce Cell with a sharp object such as a needle.
- Strictly prohibits disassemble or modify the cell.



Product Specifications

File.No: E-SPE-0135-01

Ver: 00

Page: 10/10

Date: 2017-02-15

- Strictly prohibits welding a cell directly.
- Do not use a Cell with serious scar or deformation.
- Thoroughly read the user's manual before use, inaccurate handling of lithium ion rechargeable cell may cause leakage, heat, smoke, an explosion, or fire, capacity decreasing.

! Warning

- Strictly prohibits put cell into a microwave oven, dryer, or high-pressure container.
- Strictly prohibits use cell with dry cells and other primary batteries, or new and old battery or batteries of a different package, type, or brand.
- Stop charging the Cell if charging is not completed within the specified time.
- Stop using the Cell if abnormal heat, odor, discoloration, deformation or abnormal condition is detected during use, charge, or storage.
- Keep away from fire immediately when leakage or foul odor is detected.
- If liquid leaks onto your skin or clothes, wash well with fresh water immediately.
- If liquid leaking from the Cell gets into your eyes, do not rub your eyes. Wash them well with clean edible oil and go to see a doctor immediately.

! Caution

- Before using the Cell, be sure to read the user's manual and cautions on handling thoroughly.
- Charging with specific charger according to product specification. Charge with CC/CV method. Strictly prohibits reversed charging. Connect cell reverse will not charge the cel. At the same time, it will reduce the charge-discharge characteristics and safety characteristics, this will lead to product heat and leakage.
- Store batteries out of reach of children so that they are not accidentally swallowed.
- If younger children use the Cell, their guardians should explain the proper handling.
- Before using the Cell, be sure to read the user's manual and cautions on handling thoroughly.
- Batteries have life cycles. If the time that the Cell powers equipment becomes much shorter than usual, the Cell life is at an end. Replace the Cell with a new same one.
- When not using Cell for an extended period, remove it from the equipment and store in a place with low humidity and low temperature.
- While the Cell pack is charged, used and stored, keep it away from objects or materials with static electric charges
- If the terminals of the Cell become dirty, wipe with a dry clothe before using the Cell.
- Storage the cells in storage temperature range as the specifications, Afer full discharged, we suggest that charging to 3.9~4.0V with no using for a long time.
- Do not exceed these ranges of the following temperature ranges.
Charge temperature range : 0°C to 45°C; Discharge temperature range : -20°C to 60°C.(When using equipment)

12. Statement

If our specifications material, product process or product control system has changed, the information will be transmitted to consumer by way of written with quality and reliability data.